

DAS High Performance USA

FEATURES

- ✓ Filters manufactured from polyester resin and fiber glass.
- ✓ Excellent external finish with gel coat.
- ✓ White gel coat internal coating.
- ✓ 1" collector arms injected in Polipropylene+FV
- ✓ Bed depth of 1 or 1,2 m
- ✓ Fitted with manometer and 3/4" water drain.
- ✓ Ø140mm sand drain and Ø125mm sand drain for 6 bar models.
- ✓ Maximum temperature: 50°C.
- ✓ **Maximum pressure: 4 or 6 bar.**

OPTIONAL

- ✓ Ø225mm sand drain .
- ✓ Internal vinylester coating.
- ✓ Internal coating for drinking water.
- ✓ Nozzle plate.

Code for 1m depth bed	60564?	60565?	60566?	60567?
Code for 1,2m depth bed	60568?	60569?	60577?	60578?
Model (inch)	31.5		37.4	
Connections (inch)	2"		2 1/2"	
Filtering velocity (m3/h/m2)	30			
Flow (m ³ /h)	15		21	
Maximum pressure (bar)	4	6	4	6
Sand (lb)	1168		1830	
Gravel (1-2mm)(lb)	364		573	
D (inch)	32.28		38.38	
H 1m bed depth (inch)	69.68		70.07	
H 1,2m bed depth (inch)	77.56		77.95	
M (inch)	9.05		10.63	
N (inch)	28.74		35.04	
P (inch)	22.83		27.56	

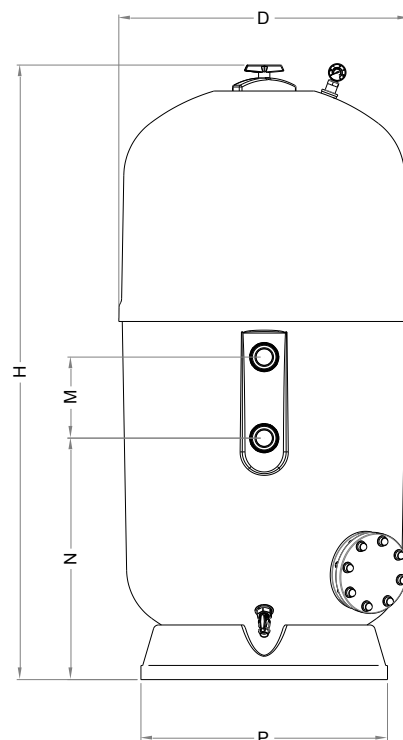

PACKAGING

Code for 1m depth bed	60564?	60565?	60566?	60567?
Code for 1,2m depth bed	60568?	60569?	60577?	60578?
Standard Units	1			
Packaging (ft)	3.28x3.28x6.23-6.89			
Volume (ft ³)	6.23-6.89			